

Prewire for Model 305, 400, 410, 519

Prewire for "S12" keypad

Prewire for all "Pan", "TES2", "Vik", "Elan", etc.

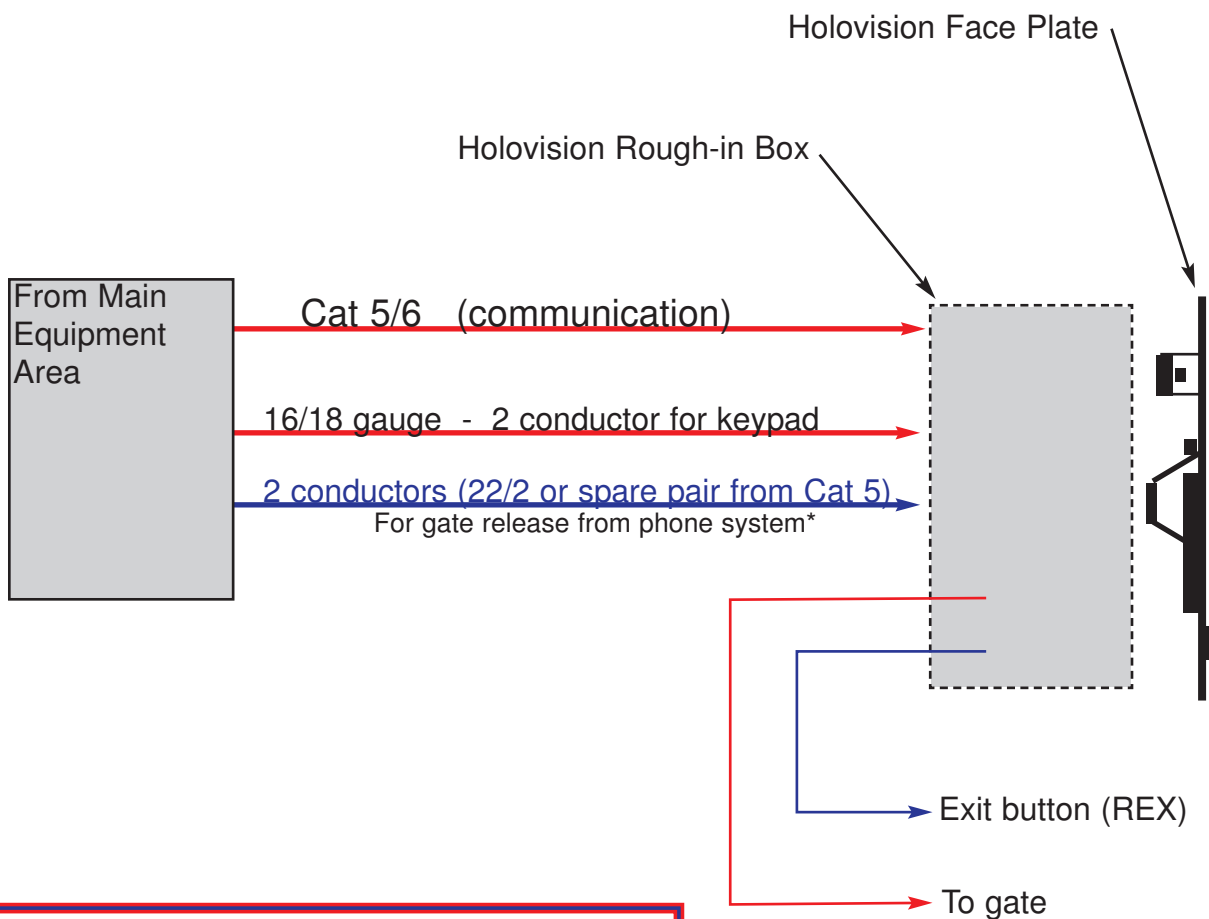

NOTE:
Wires shown in red are the minimum required
Wires shown in blue are recommended

Note on Essex Wiring: Electric motorized gates require only a contact closure from the S12 keypad. Electric strikes or mag locks can draw several amps, and the appropriate wire size should be calculated. Longer runs will require a heavier gauge wire.

Note: If the power supply shipped with the S12 (12 VDC) is used to activate the strike, the strike will receive 12 VDC. If AC is required for the strike, a separate pair of wires should be supplied.

Wire for gate release from phone system is required, but it can be a spare pair from Cat5/6

Prewire for Model 305, 400, 410, 519

Prewire for "W" keypad

Prewire for all "Pan", "TES2", "Vik", "Elan", etc.

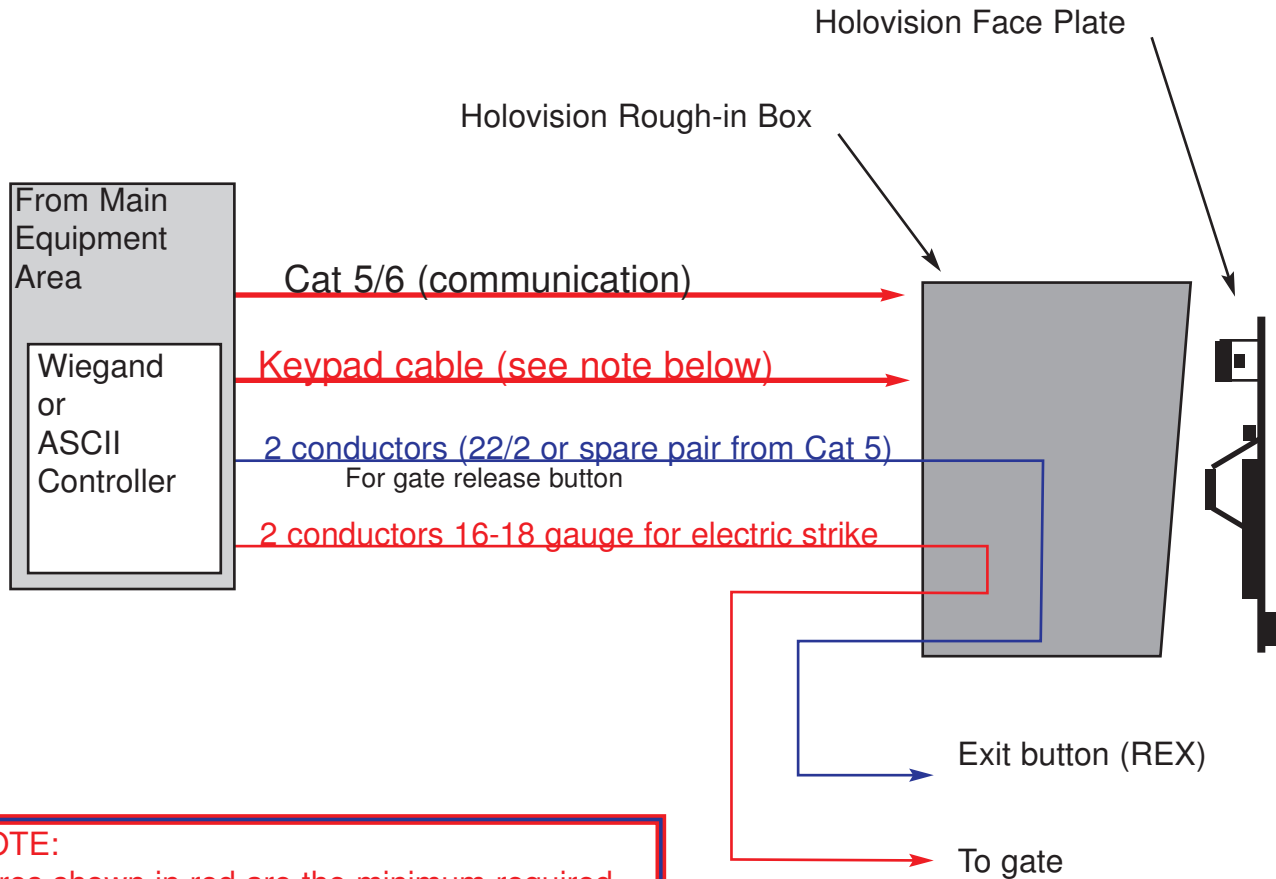

NOTE:

Wires shown in red are the minimum required

Wires shown in blue are recommended

Wiegand Keypads:

Cable Distance

Wiegand or Clock-and-Data interface: 500 feet

Recommended cable

Alpha 1295, Belden 5503FE 5 conductor, 22 AWG stranded with overall shield or equivalent

NOTE: Cat 5 / 6 cable for Wiegand keypad is NOT Recommended

ASCII Keypads:

Cable Distance

ASCII controller: 500 feet

Recommended cable

Cat 5, Cat 6

Prewire for Model 305, 400, 410, 519

Prewire for "S12" keypad

Prewire for VIO2.

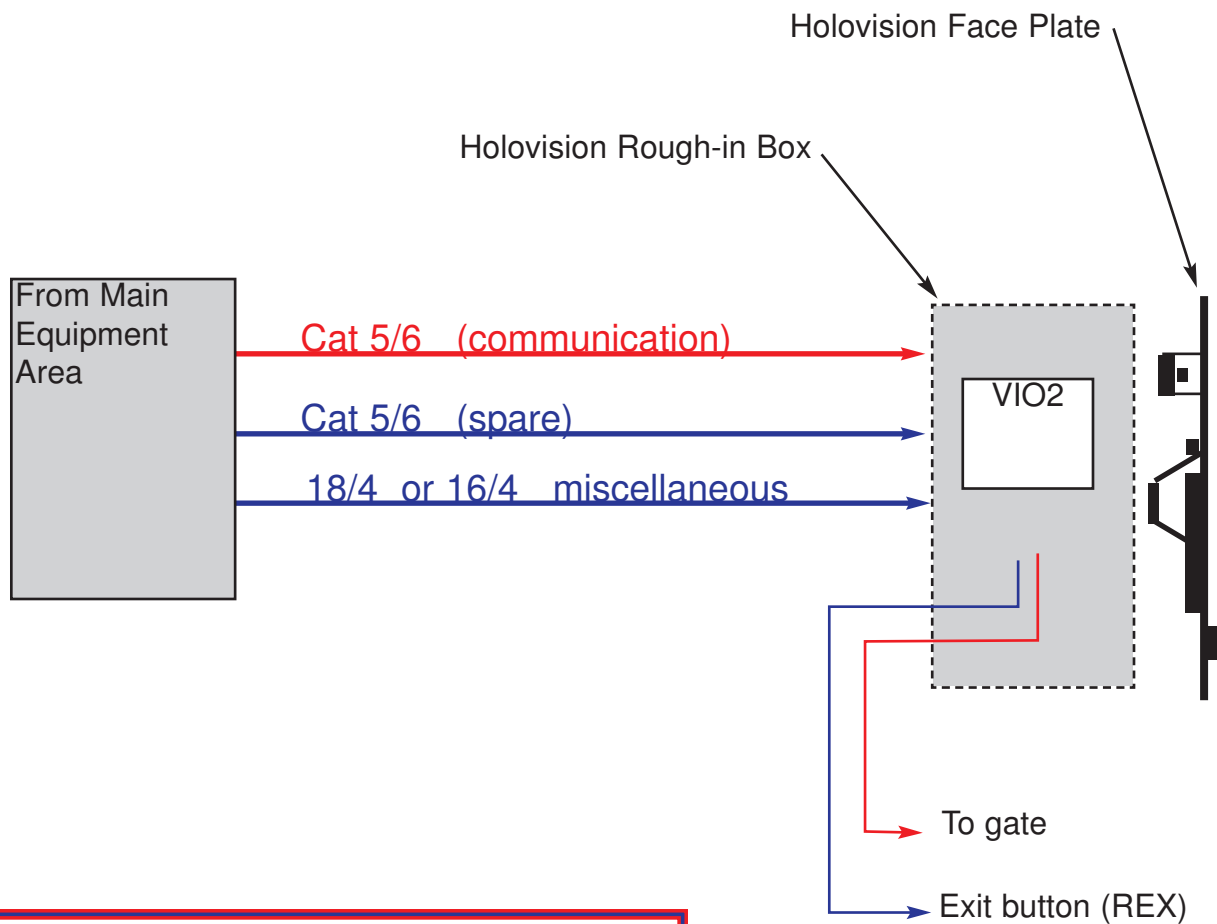

NOTE:

Wires shown in red are the minimum required

Wires shown in blue are recommended

Note: If VIO2 is used to activate the strike, the strike will receive 12 VDC. If AC is required for the strike, a separate pair of wires should be supplied.

Prewire for Model 305, 400, 410, 519

Prewire for "A, W" keypad

Prewire for VIO2

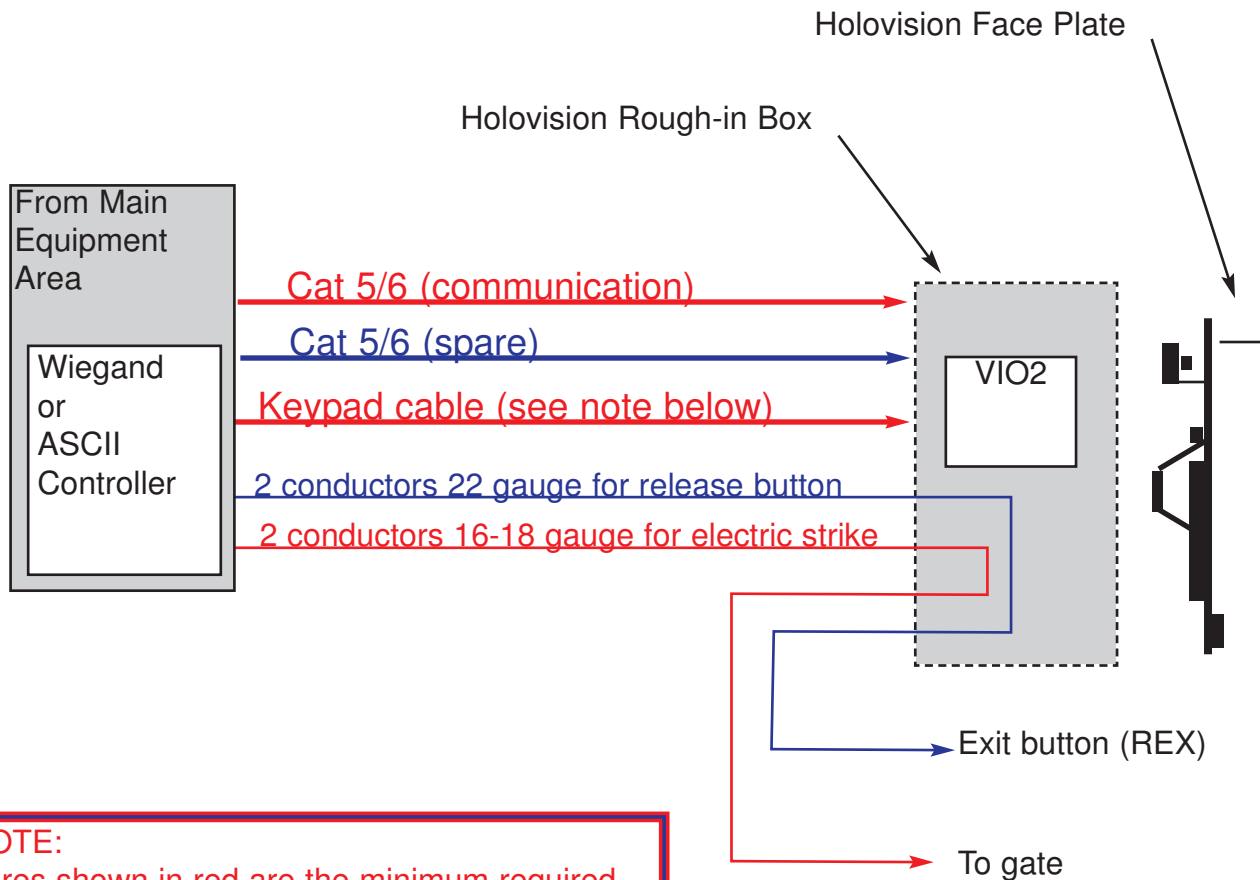

NOTE:

Wires shown in red are the minimum required

Wires shown in blue are recommended

Wiegand Keypads:

Cable Distance

Wiegand or Clock-and-Data interface: 500 feet

Recommended cable

Alpha 1295, Belden 5503FE 5 conductor, 22 AWG stranded with overall shield or equivalent

NOTE: Cat 5 / 6 cable for Wiegand keypad is NOT Recommended

ASCII Keypads:

Cable Distance

ASCII controller: 500 feet

Recommended cable

Cat 5, Cat 6

Door Station Rough-in

Model 305, 400, 410



50"

NOTE: All dimensions given are relative to "finished" surface, not rough grade.



Installation Details - 300 and 600 Series

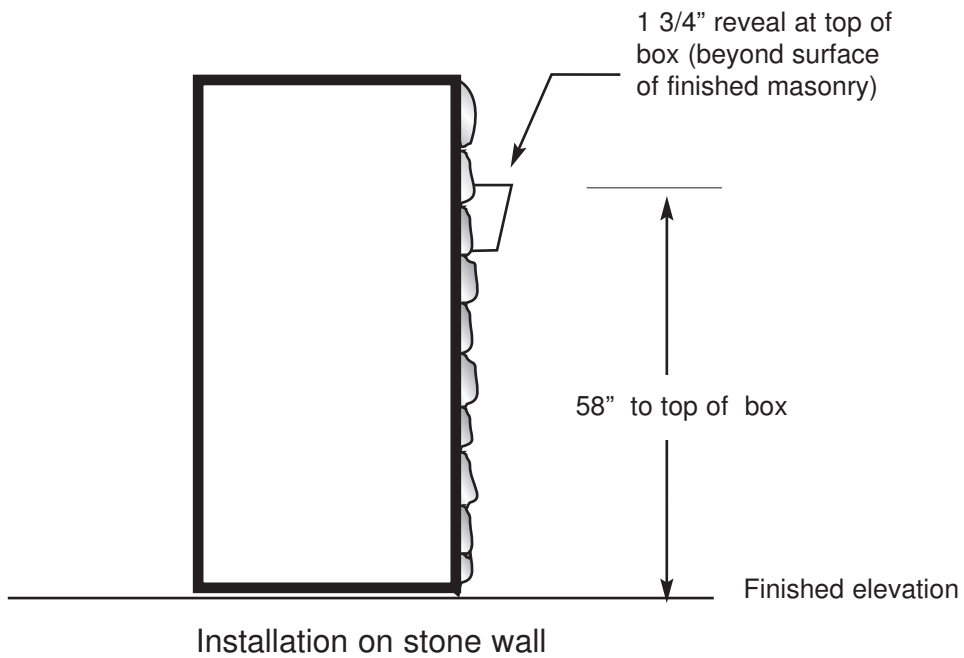
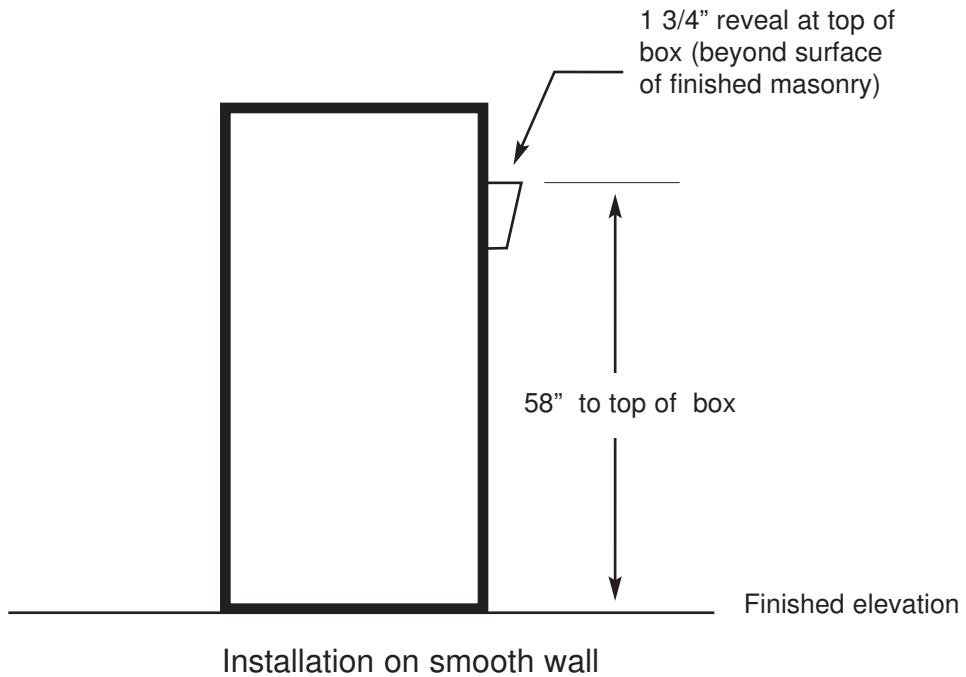

Installation Details - 2 Piece Gooseneck

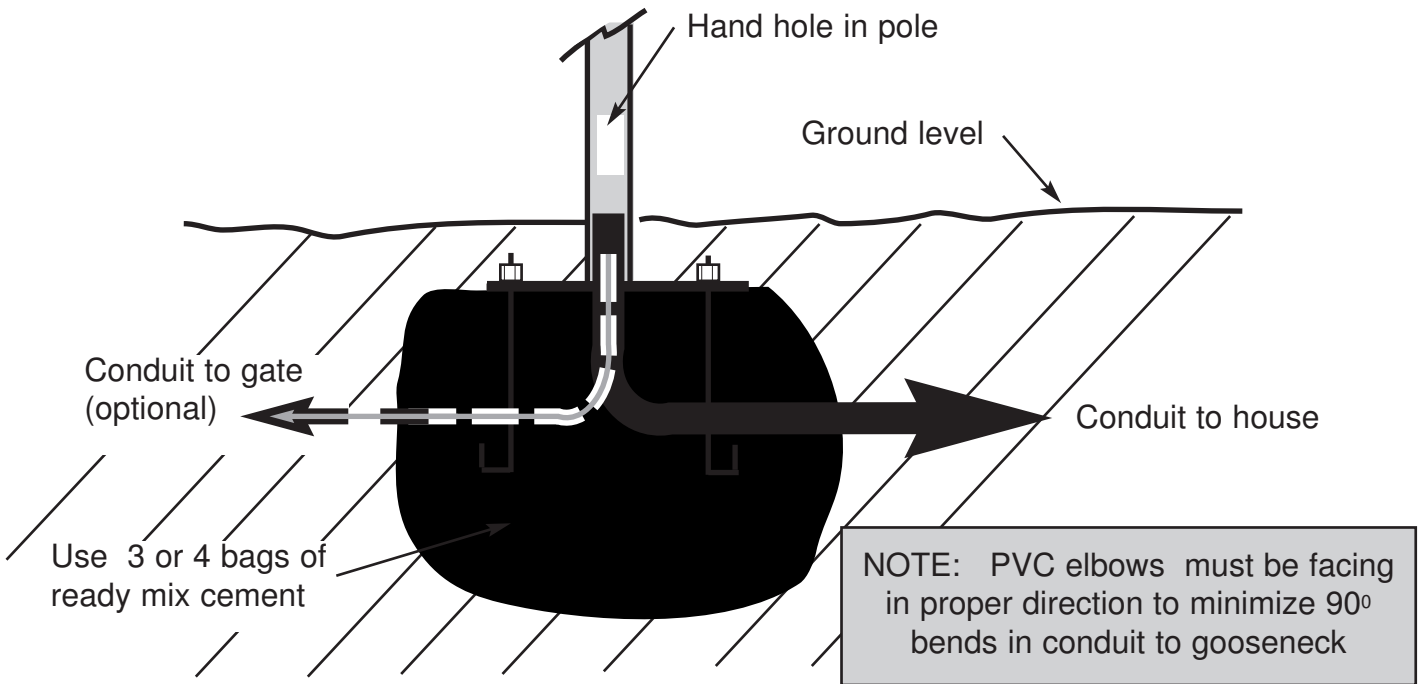
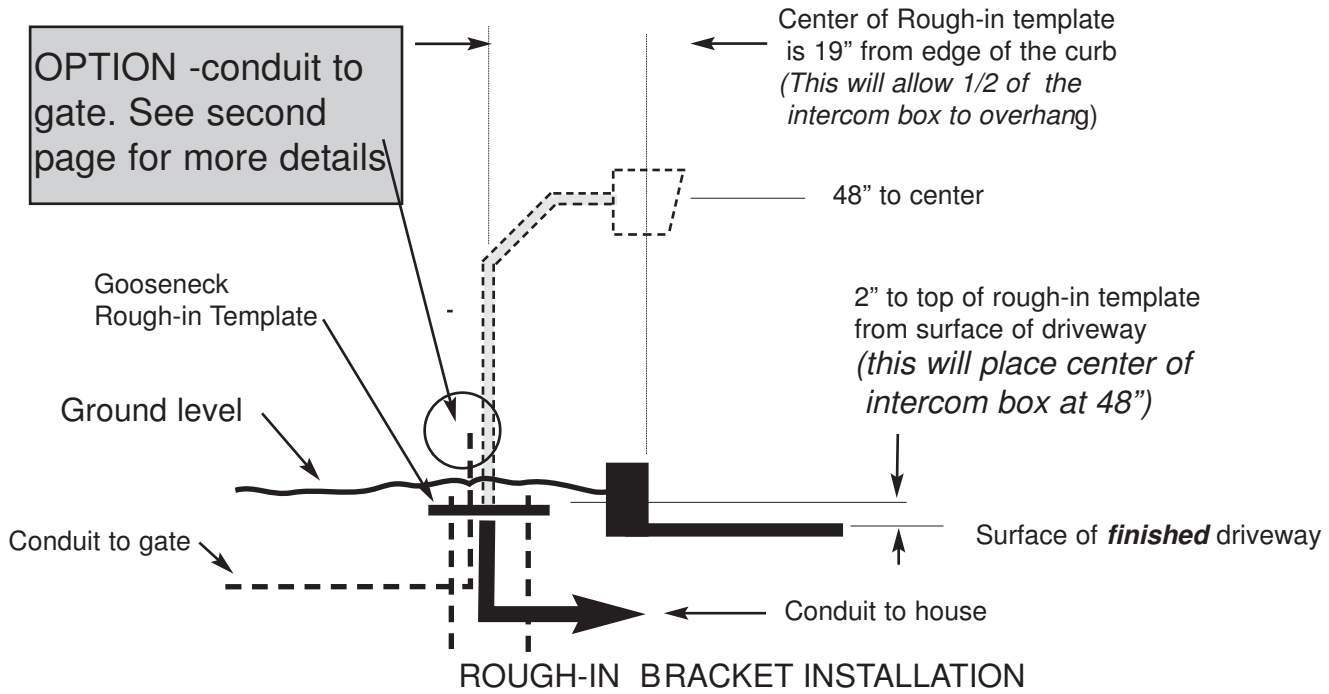

DETAIL OF ATTACHMENT OF POLE ONTO BASE

Installation Details - 2 Piece Gooseneck

Optional application with 2 conduits

