

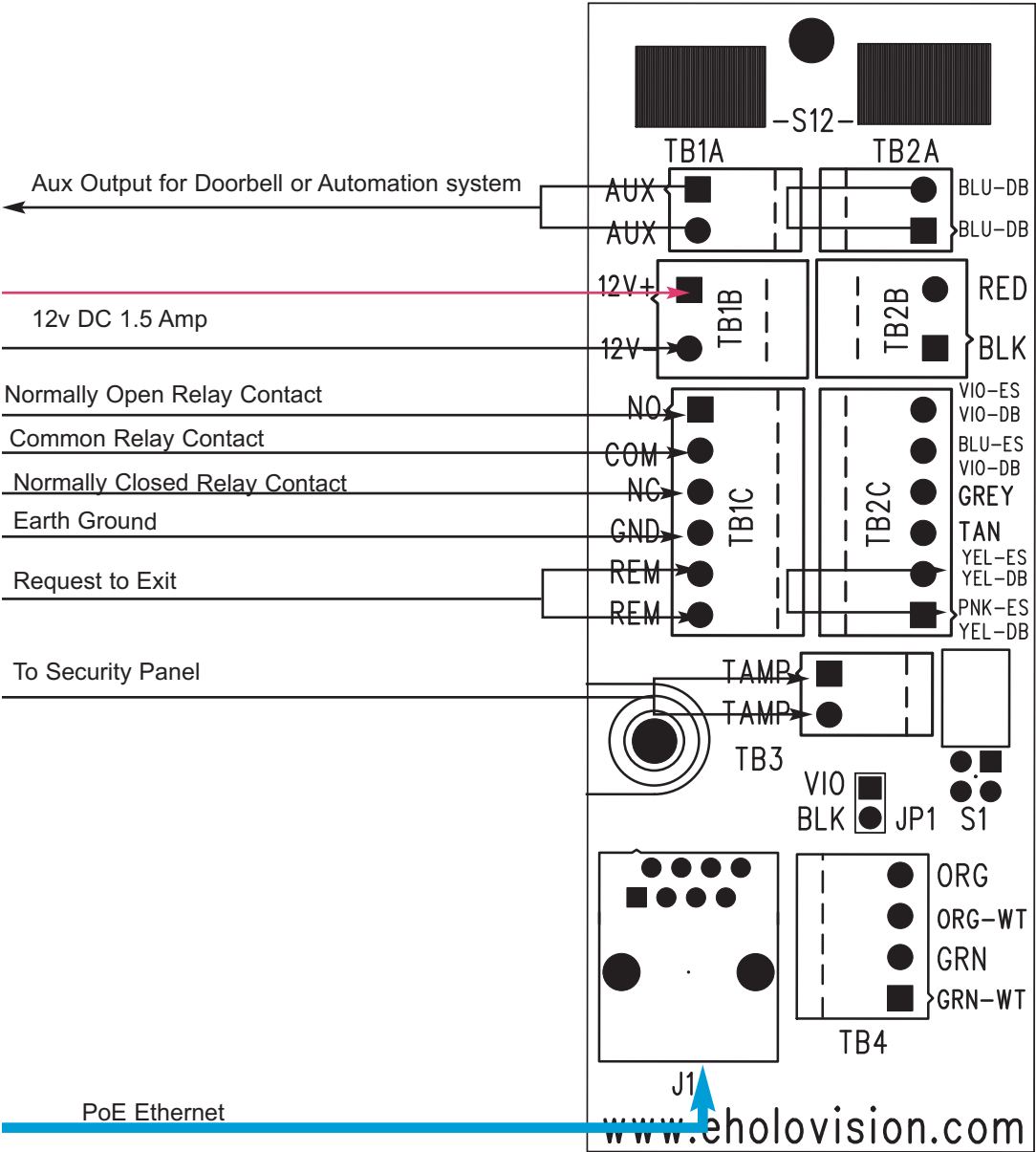

**Manual Type 6.2.0.12-  
RF**  
Model 1032

**INSTALLATION  
INSTRUCTIONS**

Specifications	
<b>Communication</b> Door Bird push forward notification	<b>Access Control</b> IEI S12 Stand Alone Keypad Request to Exit



501 E. Goetz Ave.  
Santa Ana, Ca 92707  
[www.eholovision.com](http://www.eholovision.com)

Ph. 714-434-6904  
Fax 800-362-0002

**HOLOVISION**

# Instructions for Holovision 432-DB Entry System

---

Download the "DoorBird" app by Bird Home Automation onto your mobile device from the Apple app store or Google Play store. You can always find the most up-to-date version of the App manual on [www.doorbird.com/support](http://www.doorbird.com/support)

If you use WiFi for connecting the video door station to your Internet router, first go to "Settings > WiFi Setup" and follow the instructions.

If you have finished the WiFi set-up or have connected the video door station to your Internet router by means of a network cable, go to "Settings > Add device" and click on the QR code icon in the "User" field. Scan the user QR code found on the "Digital Passport" that accompanies the video door station.

If you have problems adding the video door station to the App please check if the video door station is online ( [www.doorbird.com/checkonline](http://www.doorbird.com/checkonline) ). If the video door station is not online, please check the WiFi or network cable connection again.

Since Apple uses very high quality microphones, loudspeakers and digital audio components that are perfectly in tune with one another, the voice quality with an iPhone or iPad is usually noticeably better than with an Android smartphone or Android tablet.

## Diagnostic-LED

This LED light is only lit up for five minutes after the video door station has been supplied with power (and continuously at night). It lights up as soon as the video door station is supplied with power.

- Illuminated: Device is powered

## Diagnostic-sounds

After around two to five minutes, the video door station emits brief diagnostic sounds after it has been connected to the power grid.

- 1x diagnostic sound: The video door station is connected to the Internet
- 2x diagnostic sounds: The video door station is able to communicate with the router, but cannot access the Internet
- 3x diagnostic sounds: The video door station has no connection to the network

# Pedestrian Gate Strike

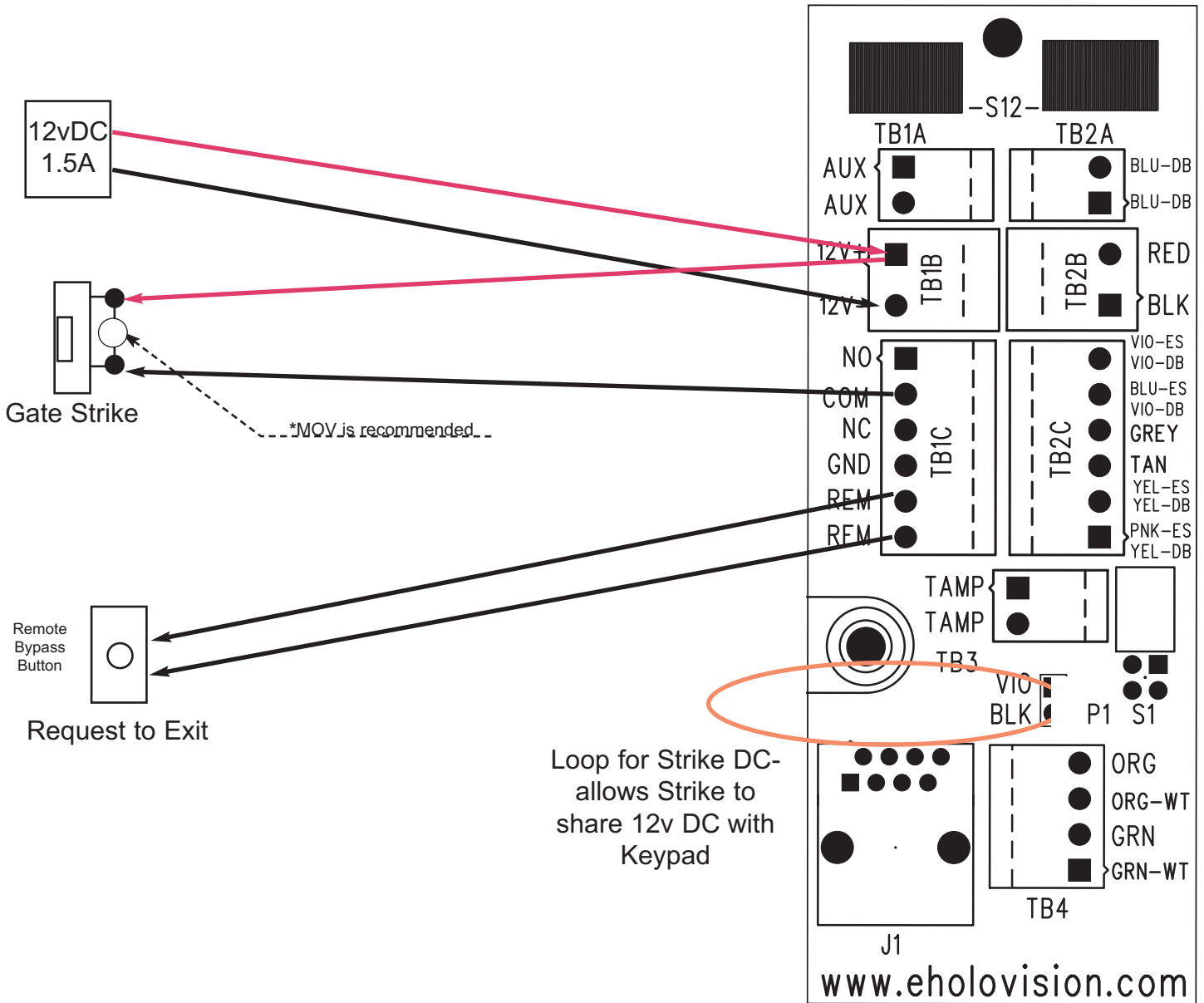

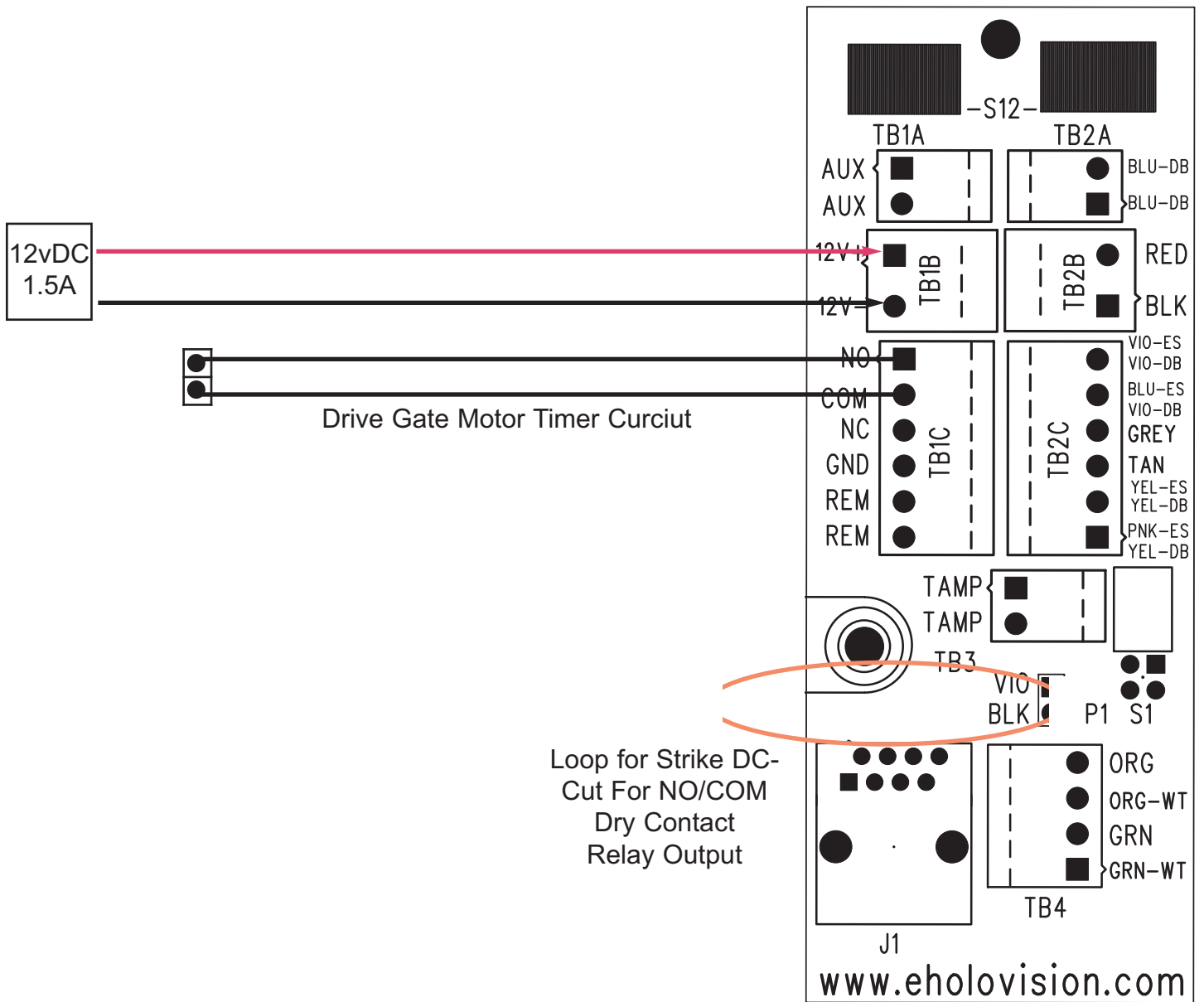

# Instructions for Holovision 1032-DB Entry System

---

Download the "DoorBird" app by Bird Home Automation onto your mobile device from the Apple app store or Google Play store. You can always find the most up-to-date version of the App manual on [www.doorbird.com/support](http://www.doorbird.com/support)

If you use WiFi for connecting the video door station to your Internet router, first go to "Settings > WiFi Setup" and follow the instructions.

If you have finished the WiFi set-up or have connected the video door station to your Internet router by means of a network cable, go to "Settings > Add device" and click on the QR code icon in the "User" field. Scan the user QR code found on the "Digital Passport" that accompanies the video door station.

If you have problems adding the video door station to the App please check if the video door station is online ( [www.doorbird.com/checkonline](http://www.doorbird.com/checkonline) ). If the video door station is not online, please check the WiFi or network cable connection again.

Since Apple uses very high quality microphones, loudspeakers and digital audio components that are perfectly in tune with one another, the voice quality with an iPhone or iPad is usually noticeably better than with an Android smartphone or Android tablet.

## Diagnostic-LED

This LED light is only lit up for five minutes after the video door station has been supplied with power (and continuously at night). It lights up as soon as the video door station is supplied with power.

- Illuminated: Device is powered

## Diagnostic-sounds

After around two to five minutes, the video door station emits brief diagnostic sounds after it has been connected to the power grid.

- 1x diagnostic sound: The video door station is connected to the Internet
- 2x diagnostic sounds: The video door station is able to communicate with the router, but cannot access the Internet
- 3x diagnostic sounds: The video door station has no connection to the network

# Programming the Keypad

## Testing the Keypad

STEP	ACTION
1	Apply 12 VDC power to red and black wires
2	Press <b>7890#123456*</b>
3	LED's will alternate Green, Yellow and Red followed by 3 beeps
4	Test default Master Code- <b>1234*</b>

## Set New Master Code

STEP	ACTION
1	<b>The default Master Code is 1234*.</b> This can be changed to a unique code 3 - 8 digits long
2	Enter Program Mode- <b>99 # 1234 *</b>
3	Enter <b>1 # new Master Code * new Master Code *</b>
4	When finished press * to exit Program Mode

## Program User Codes

STEP	ACTION
1	Enter Program Mode- <b>99 # Master Code *</b>
2	Enter Standard User Location (Standard User Locations start at 3 and go up to 500)followed by <b># New Code * New Code *</b>
3	Example <b>99 # Master Code * User Location # New Code * New Code *</b>
4	When finished press * to exit Program Mode

## Delete User Codes

STEP	ACTION
1	Enter Program Mode- <b>99 # Master Code *</b>
2	Enter <b>56 # followed by 1 (Disable) # User Location # * *</b>
3	Example <b>99 # Master Code * 56 # 1 # User Location # * *</b>
4	When finished press * to exit Program Mode

**DEFAULT USER CODE & MASTER CODE IS "1234\*"**

# Programming the Keypad

---

## Set Relay Duration Time

STEP	ACTION
1	Enter Program Mode- <b>99 # Master Code *</b>
2	Enter <b>11 # followed by desired time (1 to 255 seconds) # 0 # * *</b>
3	Example <b>99 # Master Code * 11 # 20 # 0 # * *</b>
4	When finished press * to exit Program Mode

## Program a Latching Code

STEP	ACTION
1	Enter Program Mode- <b>99 # Master Code *</b>
2	Enter <b>60 # 0 # User Location # Code * Code *</b>
3	Example <b>99 # Master Code * 60 # 0 # User Location # Code * Code *</b>
4	When finished press * to exit Program Mode
5	To activate Latching enter latching Code. To Unlatch enter Code Again